

JAGUAR XF



THE ART OF PERFORMANCE





BY APPOINTMENT TO
HM THE QUEEN
MANUFACTURERS OF
MOTOR VEHICLES
JAGUAR LAND ROVER LIMITED
COVENTRY



BY APPOINTMENT TO
HRH THE DUKE OF EDINBURGH
MANUFACTURERS OF
MOTOR VEHICLES
JAGUAR LAND ROVER LIMITED
COVENTRY



BY APPOINTMENT TO
HRH THE PRINCE OF WALES
MANUFACTURERS OF
MOTOR VEHICLES
JAGUAR LAND ROVER LIMITED
COVENTRY



JAGUAR

THE ART OF PERFORMANCE

Every day we push performance to its limit. Our performance. Our cars' performance.
We innovate, we engineer, we design. We master rules and then break them.
Only to push further. Past the limits of convention. This is when performance becomes art.

Jaguar. The Art of Performance.





CONTENTS

INTRODUCTION

The Concept of XF	06
XF - The Facts	08

DESIGN

Exterior Principles	10
Exterior Aerodynamics	13
Interior	15
Interior Space	17

PERFORMANCE

Engines Overview	18
Advanced Aerodynamics	20
Lightweight Aluminium Architecture	23
Chassis and Suspension	24

DRIVING TECHNOLOGY

Advanced Driving Dynamics	26
Added Driver Confidence	28
Torque Vectoring	31
Stability and Control	33

TECHNOLOGY

Infotainment	35
Connectivity	36
Audio	38

SAFETY AND EFFICIENCY

Driver Assistance	40
-------------------	----

PERSONALISATION

XF - Your Choice	42
Choose your Engine	44
Choose your Model	45
Choose your Options	46
Choose your Colour	50
Choose your Wheels	52
Choose your Interior	53
Choose your Jaguar Gear - Accessories	62

TECHNICAL SPECIFICATIONS

66

SPECIAL VEHICLE OPERATIONS

70

THE WORLD OF JAGUAR

72

AT YOUR SERVICE

75

VEHICLES SHOWN: XF SALOON R-SPORT IN CORRIS GREY WITH OPTIONAL FEATURES FITTED (MARKET DEPENDENT)

VEHICLES SHOWN ARE FROM THE JAGUAR GLOBAL RANGE. SPECIFICATIONS, OPTIONS AND AVAILABILITY MAY VARY BETWEEN MARKETS AND SHOULD BE VERIFIED WITH YOUR LOCAL JAGUAR RETAILER.

INTRODUCTION

THE CONCEPT OF XF

XF builds on the success of Jaguar's most award-winning car ever. Possessing an unrivalled combination of style and substance, it delivers an utterly seductive blend of design, dynamics and refinement to create a car that offers both excitement and efficiency. All enhanced by state-of-the-art technologies that keep you safe, connected and entertained.

XF sits in the Jaguar range between XE's taut athleticism and the supreme luxury of XJ. The fusion of these outstanding Jaguar attributes is what creates XF - the most dynamic, premium business car of its generation.

VEHICLE SHOWN: XF R-SPORT IN CORRIS GREY WITH OPTIONAL FEATURES FITTED (MARKET DEPENDENT)





XF - THE FACTS

An outstanding combination of advanced engineering, the latest technology and contemporary design sets XF apart.

ADVANCED AERODYNAMICS

XF is capable of achieving a drag coefficient of just Cd 0.26, one of the lowest in its class. Even the underside of the car is aerodynamically designed to be as smooth as possible, while apertures in the front bumper optimise airflow through the wheel arches. XF cuts through the air, reducing wind noise for enhanced refinement and improved efficiency.

CRAFTSMANSHIP AND SPACE

Contemporary craftsmanship and a luxurious, practical interior with the space to stretch out and enjoy every journey. Your front and rear passengers will appreciate leg, knee and headroom that are among the best in class. The 40:20:40* rear seating configuration increases volume and versatility.

*Standard on Portfolio.

VEHICLE SHOWN: XF S IN YULONG WHITE WITH OPTIONAL FEATURES FITTED
(MARKET DEPENDENT)

LIGHTWEIGHT ALUMINIUM ARCHITECTURE

XF's Lightweight Aluminium Architecture creates an incredibly strong body that delivers precise and responsive sports handling with impressive fuel efficiency.

ADDED INTELLIGENCE

Innovative technologies make every drive easier and safer. XF offers Adaptive LED headlights, All Surface Progress Control, Cruise Control and Speed Limiter, as well as Park Assist.



CONNECTIVITY

Every drive in XF is enhanced by InControl technologies. InControl is a suite of products and services that connects you with your XF and links it to the wider world. It ensures you are always in touch.



DESIGN EXTERIOR PRINCIPLES

 DESIGN PURITY | ADAPTIVE LED HEADLIGHTS

VEHICLE SHOWN RIGHT: XF R-SPORT IN CORRIS GREY WITH OPTIONAL FEATURES FITTED (MARKET DEPENDENT)

"It's about paring it down to the bare essentials. Good designers have always said less is more."
Ian Callum, Jaguar Design Director.

XF demonstrates the Jaguar principles of design purity. Strong lines radiate dynamic character and enhance its capabilities – be it improving aerodynamics, visibility, stability or safety. XF is available with Adaptive LED headlights*, featuring Jaguar signature 'J' blade Daytime Running Lights to give XF a striking on-road presence. The quality of LED light is close to daylight, helping your eyes to distinguish objects more easily and reducing fatigue at night.

*Standard on Prestige and Portfolio. Xenon headlights standard on Pure.







EXTERIOR AERODYNAMICS



AERODYNAMIC DESIGN

F-TYPE INSPIRED DESIGN

XF's sweeping exterior design is naturally aerodynamic. Its advanced form enhances handling, dynamics and refinement. Airflow is carefully managed through and around the car. Intakes either side of the front grille draw air in, then channel it out from the wheel arches to reduce turbulence. As air flows along the car, pressure differences that can cause drag are minimised by the flush, aerodynamically optimised sides.

At the rear, XF's tail lights feature a distinctive, F-TYPE inspired roundel and intersecting horizontal detail. The LED brake lights are not only brighter than halogen bulbs, they use less energy - contributing to XF's overall drive for greater efficiency. LEDs also illuminate faster, so following drivers can react more quickly to XF's braking. Within the tail lights is a pinstripe graphic - one of XF's many exquisite finishing touches.

VEHICLE SHOWN: XF S IN YULONG WHITE WITH OPTIONAL FEATURES FITTED (MARKET DEPENDENT)



JAGUAR

140 180 220 260 300
0
km/h

3 4 5
P
R N D S



S

HOME 14:56

Navigation	Media	Phone
Arlington Avenue Leamington Spa P 65 km 16:25	Bluetooth audio Young Before Your Time Corvidae	My iPhone

16.5

SYNC

MAX MAX A/C A/C

START STOP

P R N D S



INTERIOR



**DRAMATIC START-UP
SEQUENCE**

**CONTEMPORARY
CRAFTSMANSHIP**

Open XF's door and the Start button entices you inside. Pulsing with a heartbeat, it creates an emotional connection between driver and machine. Its 72 per minute double beat is the same as a jaguar cat at rest. XF is poised, ready for action. Now push the Start button. The car awakens and its mood lighting illuminates. With perfect choreography, air vents rotate open, the JaguarDrive Selector rises smoothly, and the engine growls - all inspiring you to anticipate the drive ahead.

XF's interior offers outstanding comfort, a sense of wellbeing and a wealth of choice. The number of switches and buttons is kept to a minimum to keep the look clean and tidy, as well as making them easy to use. Whichever XF interior combination you choose, the materials used are always of the highest quality. Leather and finishes are selected with the greatest care to ensure that, inside XF, everything is luxurious to the touch. Whether you prefer Aluminium, Carbon Fibre or Wood veneer finishes to complement the beautiful selection of leathers, your XF will always look and feel just right.

INTERIOR SHOWN: XF S FEATURING LIGHT OYSTER/EBONY SEATS WITH EBONY UPPER FACIA AND CONTRAST STITCH, EBONY CARPET AND EBONY HEADLINING WITH OPTIONAL FEATURES FITTED (MARKET DEPENDENT)





1. Headroom 957 mm 2. Knee room 87 mm

INTERIOR SPACE



GENEROUS REAR SPACE

IMPRESSIVE VERSATILITY

The rear of XF's cabin is a destination of luxury, choice and space. The generous rear knee room is among the best in class, while the ample rear legroom and rear headroom gives you room to relax. It all adds up to greater comfort and wellbeing for passengers.

Interior lighting also enhances XF's atmosphere. Opt for Configurable Ambient Interior Lighting and you'll have a choice of ten interior colours.

INTERIOR SHOWN: XF S FEATURING LIGHT OYSTER/EBONY SEATS WITH CONTRAST STITCH, EBONY CARPET AND EBONY HEADLINING WITH OPTIONAL FEATURES FITTED (MARKET DEPENDENT)

PERFORMANCE ENGINES OVERVIEW



INGENIUM ENGINE

STOP/START TECHNOLOGY

Ingenium technology underpins the diesel engine in XF. The low friction, all-aluminium engine has stiff cylinder blocks and twin balancer shafts to ensure inherently low levels of vibration, for smooth day-to-day performance. The engine is equipped with Stop/Start technology and smart regenerative charging – harvesting kinetic energy from braking to charge the battery – for maximum economy, especially during urban driving.



INGENIUM DIESEL ENGINE

0-100 km/h in 8.4 s*

The **Ingenium 2.0 I 4-cylinder 132 kW Turbocharged Diesel** offers impressive performance and economy. For an engine of this size it offers high levels of torque, but not at the expense of efficiency – a balance achieved thanks to its variable geometry turbocharger. Adapting to the changing flow of exhaust gases, it maximises low speed torque for broad power and responsiveness that is uniform, progressive and avoids lag.

*For detailed XF Saloon Technical Specifications, see pages 66-67.

XF offers a choice of two petrol engines from our Ingenium range. With their lightweight, all-aluminium design, and widespread use of low-friction roller bearings, Ingenium Petrol engines are built for smooth, highly efficient performance. All engines are equipped with Stop/Start technology and smart regenerative charging - harvesting kinetic energy from braking to charge the battery - for maximum economy, especially during urban driving.



INGENIUM PETROL ENGINES UP TO 0-100 km/h in 6.7 s

The **Ingenium 2.0 I 4-cylinder 147 kW Turbocharged Petrol** engine offers the drivability of larger engines, but with much lower fuel consumption. Direct fuel injection from centrally mounted solenoid injectors ensures precise delivery of fuel for highly efficient and clean combustion. Intelligent Continuously Variable Valve Lift control manages early or late opening of inlet valves, meaning the engine can adapt its performance to all driving situations. This works with dual independent variable cam timing to optimise power at all speeds.

The **Ingenium 2.0 I 4-cylinder 184 kW Turbocharged Petrol** engine delivers outstanding usable power and torque. For excellent acceleration and effortless overtaking, maximum torque is available at 1500 r/min. This engine's twin scroll turbocharger is fed by an integrated exhaust manifold that synchronises exhaust pulses from two separate pairs of cylinders - significantly reducing turbo lag and improving engine response.

ADVANCED AERODYNAMICS



LOW DRAG

| CD 0.26

XF's form has been rigorously optimised for aerodynamic efficiency and stability at motorway speeds. With a drag coefficient from Cd 0.26, XF cuts through the air - reducing fuel consumption and lowering emissions. Every element exploits the exterior's maximum aerodynamic potential while preserving XF's stunning proportions. Vertical apertures in the front bumper outer edges channel air through vents in the wheel arches and out over the front wheels. The airflow then passes along XF's sides where the doors have a flatter cross sectional profile to minimise air pressure differences and contribute further to reduced drag. Even the extensive under body protection is designed to make XF as efficient, economical and refined as possible.

VEHICLE SHOWN: XF PORTFOLIO IN SANTORINI BLACK WITH OPTIONAL FEATURES FITTED (MARKET DEPENDENT)



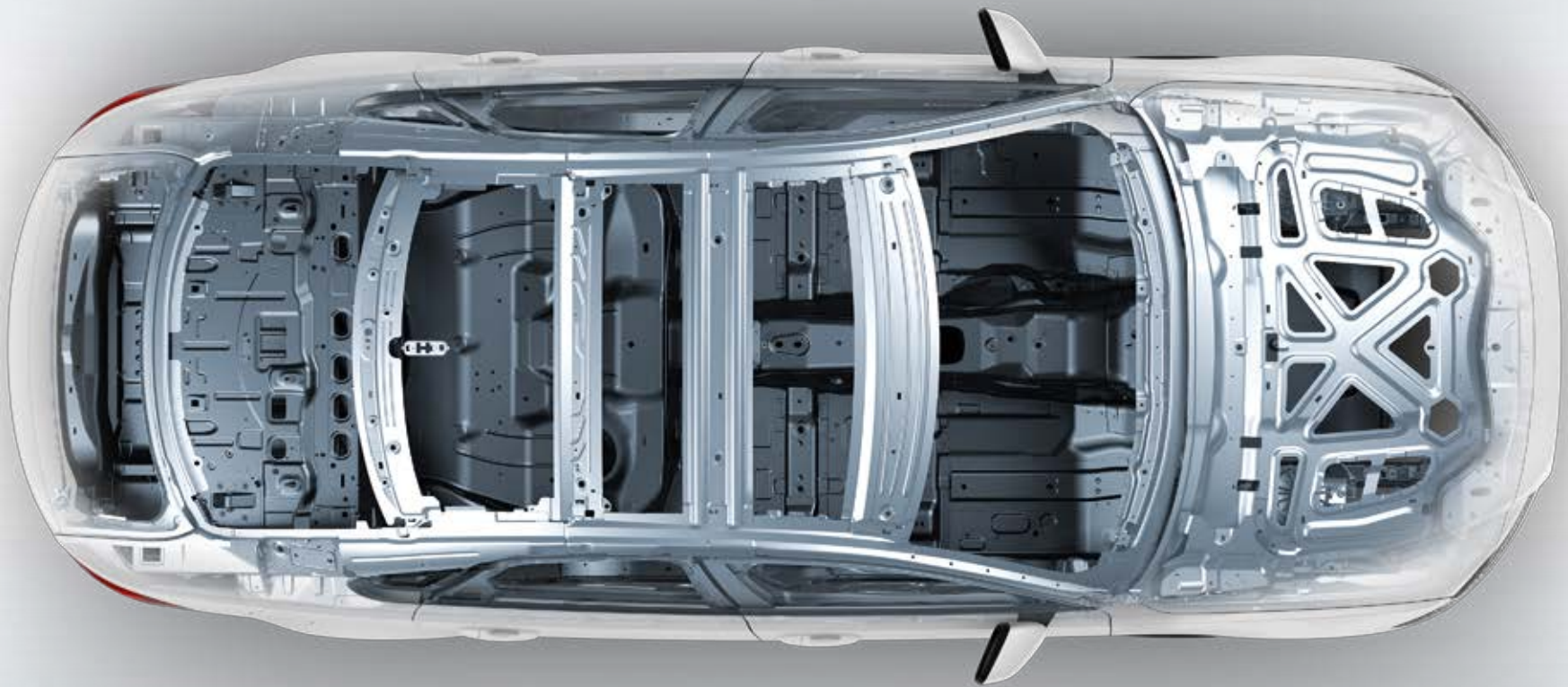

LIGHTWEIGHT ALUMINIUM ARCHITECTURE

 **STRONG** | **RIGID** | **75 % ALUMINIUM**

Jaguar has been at the forefront of aluminium car construction for more than a decade. The latest innovation is our high-strength Lightweight Aluminium Architecture, which is not only incredibly strong and reduces weight, it is also extremely stiff - underpinning XF's precise, agile handling. Aluminium has also been used to form the body sides, bonnet and front wings. These panels are bonded together with a super-strong adhesive, then punched with zinc-coated, boron steel rivets that compress the adhesive to form an airtight bond and a phenomenally strong, rigid structure. This cutting-edge process, coupled with the Lightweight Aluminium Architecture, makes XF among the lightest cars in its class.

For detailed XF Saloon Technical Specifications, see pages 66-67.

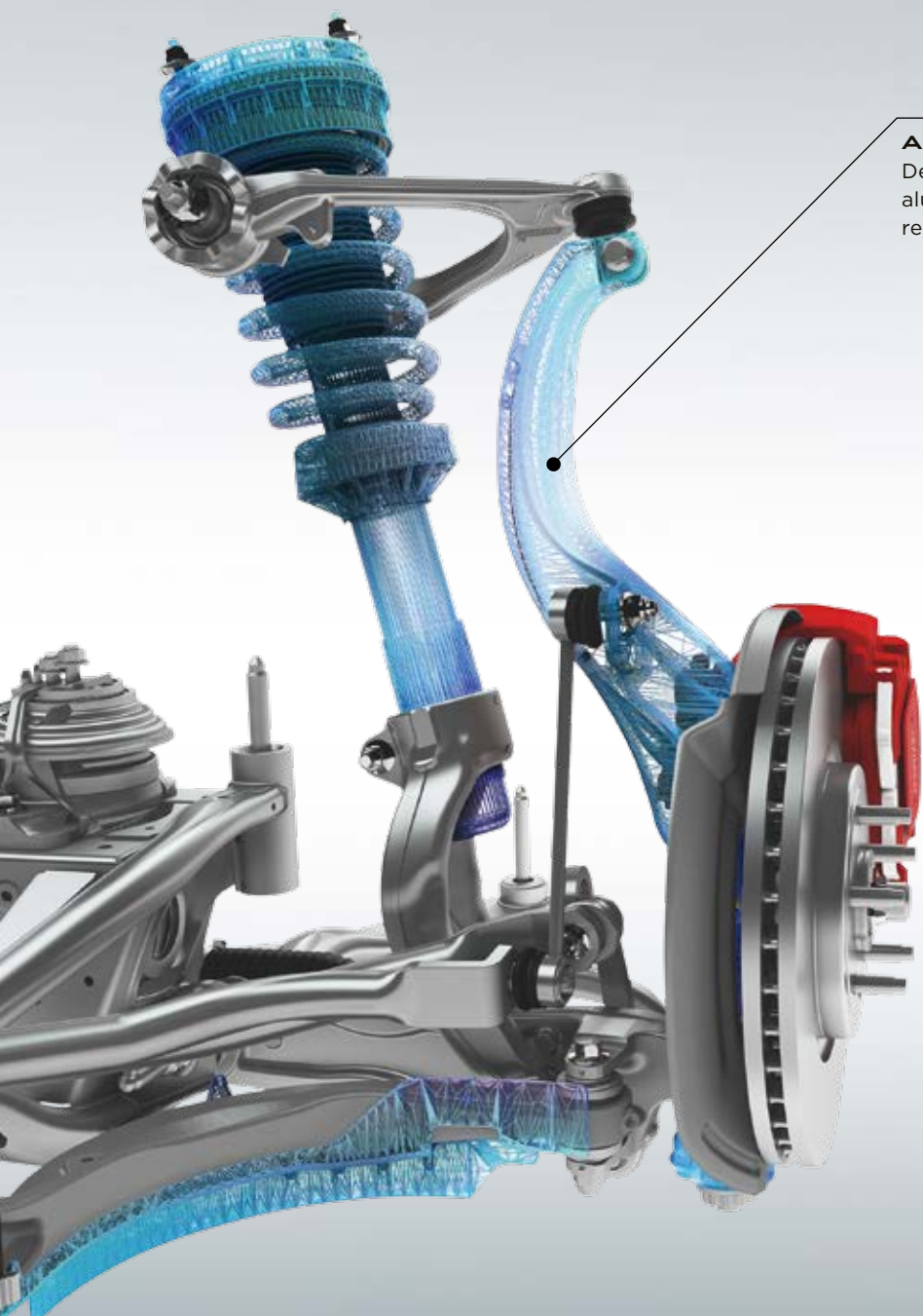

ALUMINIUM FRONT KNUCKLE

Designed to optimise stiffness and strength, the lightweight aluminium front knuckle helps improve XF's agility, responsiveness and refinement for sports car-like control.

CHASSIS AND SUSPENSION



UNIQUE SUSPENSION
TECHNOLOGY

COMFORTABLE
AND DYNAMIC

XF responds with agility and performs with dynamism while always maintaining ride comfort - it's a unique balance that makes it a Jaguar. The ideal foundation for these driving dynamics is XF's light, yet exceptionally strong and stiff, Lightweight Aluminium Architecture with its near 50:50 weight distribution.

The sophisticated front and rear suspension systems complete a chassis that achieves a superb combination of sportiness and refinement.

INTEGRAL LINK REAR SUSPENSION

Integral Link suspension allows XF to realise a perfect combination of a refined, luxurious ride and sharp, responsive handling. The system, the benchmark for this class of car, separates and independently manages the lateral, longitudinal and vertical forces acting on the suspension for enhanced control and comfort. Many components are forged or hollow-cast in aluminium - the optimum production techniques for strong, lightweight suspension.

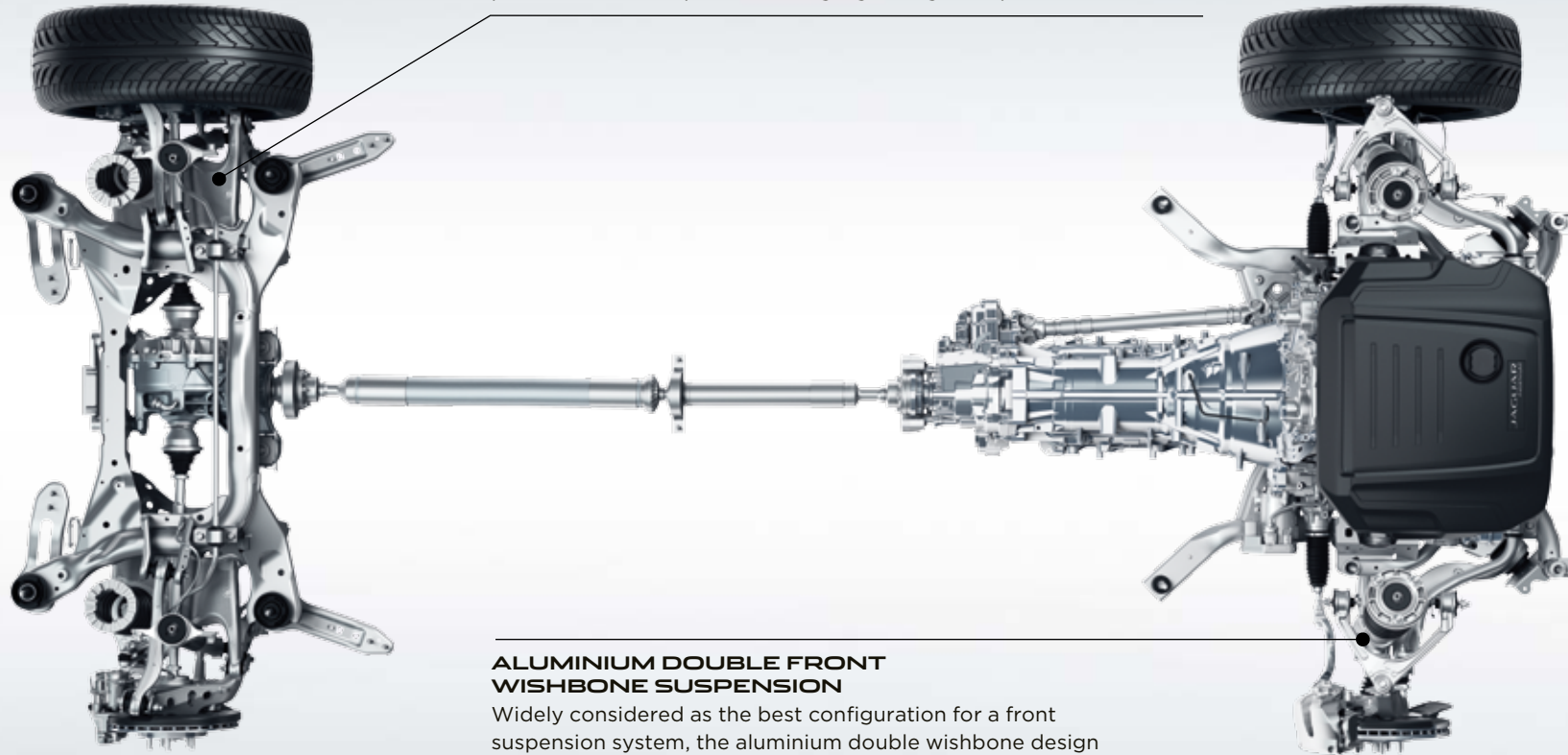

ALUMINIUM DOUBLE FRONT WISHBONE SUSPENSION

Widely considered as the best configuration for a front suspension system, the aluminium double wishbone design is modelled closely on F-TYPE's for precise handling and steering response.

DRIVING TECHNOLOGY

ADVANCED DRIVING DYNAMICS

 MAXIMISING AGILITY

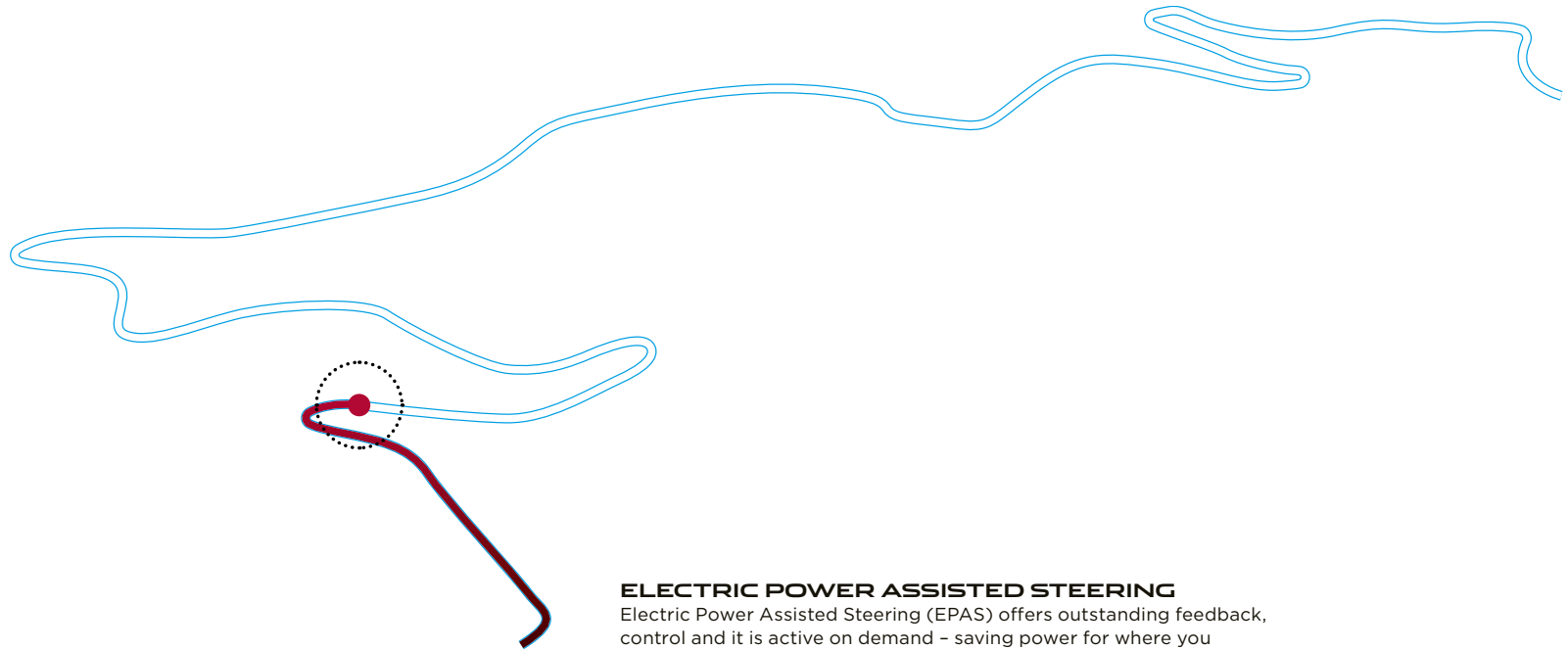

ELECTRIC POWER ASSISTED STEERING

Electric Power Assisted Steering (EPAS) offers outstanding feedback, control and it is active on demand - saving power for where you really need it, as well as saving fuel. EPAS' sophisticated computer management varies steering assistance as appropriate - increasing assistance for low speed manoeuvring and improving feel at higher speeds.



ADDED DRIVER CONFIDENCE



ALL SURFACE PROGRESS CONTROL

ADAPTIVE SURFACE RESPONSE

Unique in this class of car, Jaguar's All Surface Progress Control (ASPC) technology is a low speed cruise control that helps XF to cope with low traction situations. ASPC allows the driver to concentrate on steering the vehicle. Once activated, you use the cruise control buttons to set a 'target' speed of between 3.6 km/h and 30 km/h. The system then works to achieve and maintain that speed while exerting optimum traction control.

ASPC is standard on all engines fitted with automatic transmission and gives XF drivers added confidence over slippery, loose or icy surfaces, undulating terrain and even while descending a difficult incline. It helps make XF easy to drive in challenging conditions. ASPC also has a pull-away function allowing XF to progress from rest on low-grip surfaces and ascending gradients, as well as a hill descent function that controls vehicle speed on steeper inclines.

With any given set of tyres, ASPC can accomplish comparable levels of traction to that achievable by an expert driver. Fitting all-season or winter tyres to XF can improve capability on slippery surfaces.



GRAVEL



WET GRASS



SNOW/ICE



WET ROAD



TORQUE VECTORING

> MAXIMISED CORNERING CAPABILITY

XF's Torque Vectoring by Braking maximises capability through even the tightest corners. Torque Vectoring technology provides controlled independent braking on the individual inside front and rear wheels to add to the turning forces acting on the car. In most conditions more braking pressure is applied to the rear inside wheel as this supports the most increased cornering capability, while the front inside wheel is braked for greater effectiveness and refinement. The result is reduced understeer for sharper turning and more consistent road holding. Torque Vectoring delivers increased sports car-like agility and added driver confidence.

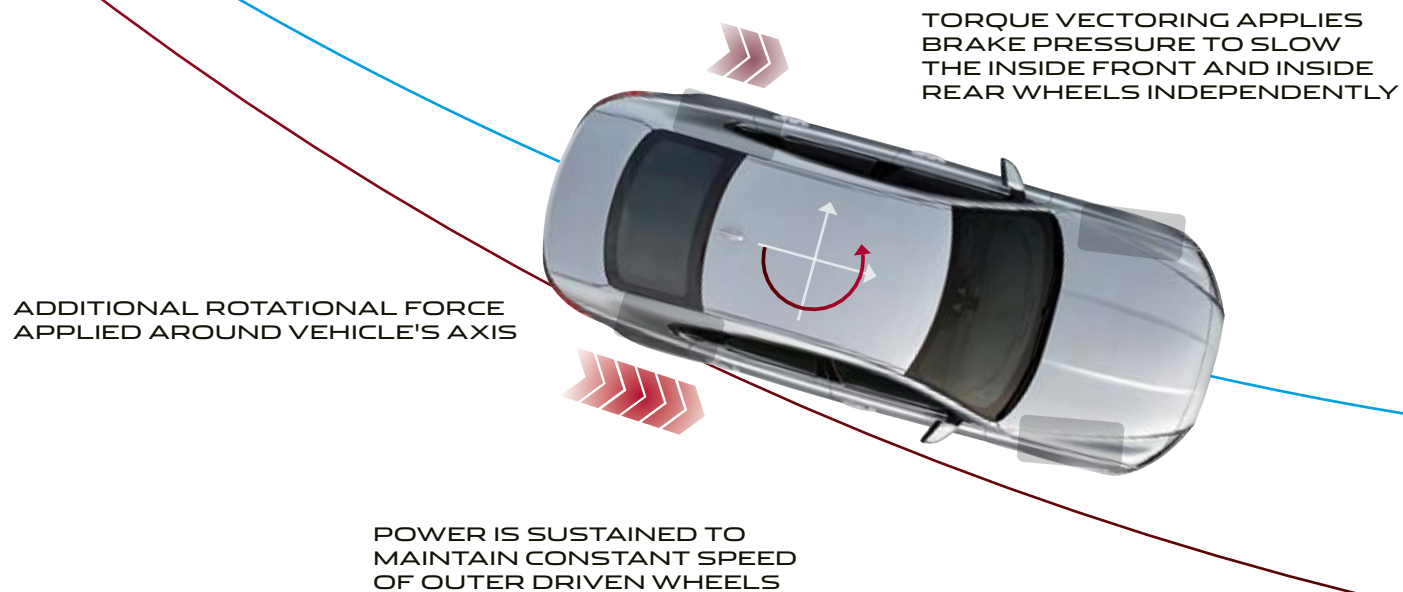

Graphical representation only.

VEHICLE SHOWN PREVIOUS PAGE: XF S IN YULONG WHITE WITH OPTIONAL FEATURES FITTED (MARKET DEPENDENT)



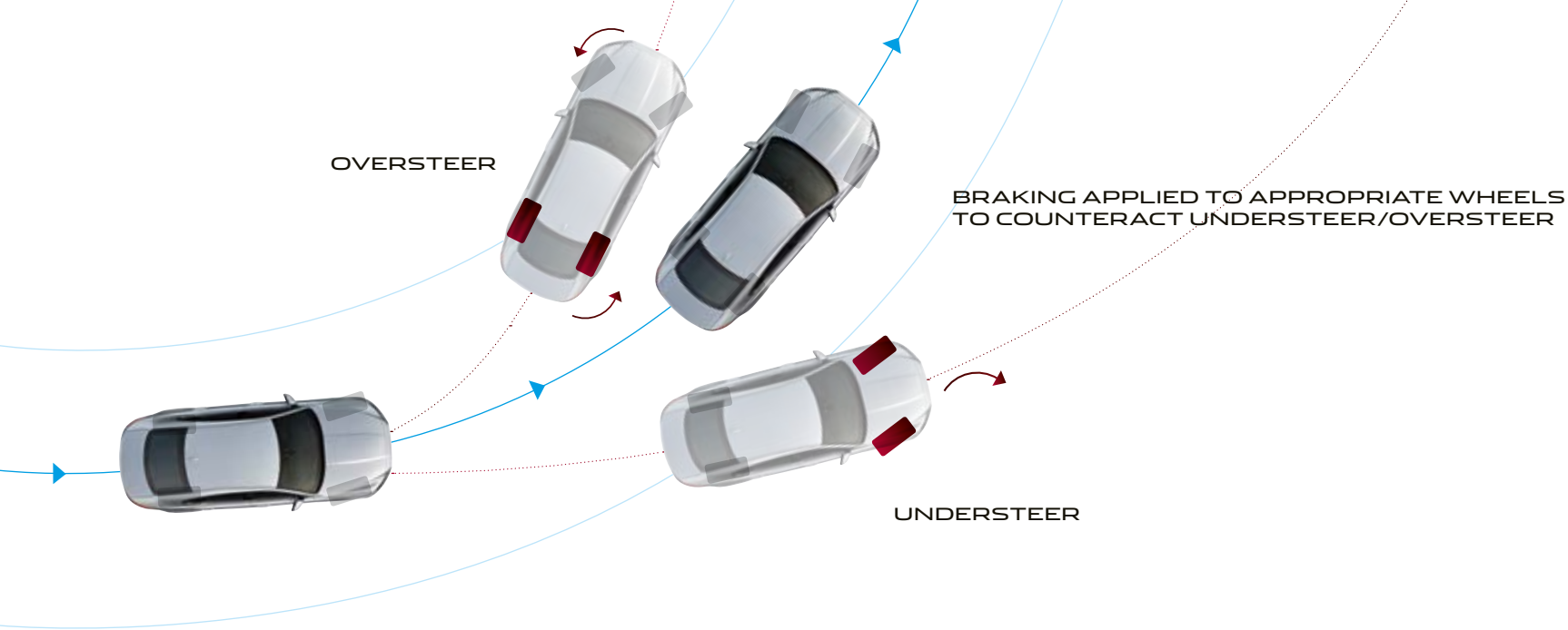

STABILITY AND CONTROL



DYNAMIC STABILITY CONTROL

ENGINE DRAG TORQUE CONTROL

Jaguar's Stability Systems keep XF safely balanced whether you're driving enthusiastically or simply want the assurance of a car that will remain stable in challenging conditions.

Dynamic Stability Control (DSC) monitors XF's dynamic behaviour, intervening to maximise vehicle stability and optimising available grip. DSC reduces engine torque and applies braking to the appropriate wheels to correct the car's direction of travel by counteracting understeer or oversteer. XF's DSC system has enhanced understeer control to reduce speed and regain control more effectively.

Engine Drag Torque Control (EDC) mitigates the chance of wheel lock-up caused by strong engine braking in slippery conditions. It acts by briefly increasing torque to the driven wheels as appropriate.

Graphical representation only.

VEHICLE SHOWN PREVIOUS PAGE: XF S IN YULONG WHITE WITH OPTIONAL FEATURES FITTED (MARKET DEPENDENT)



JAGUAR



HOME 14:56

Navigation Arlington Avenue Leamington Spa 65km 16:55	Media Bluetooth audio Young Before Your Time Corvidae	Phone My iPhone
--	--	--------------------

21.5 16.5

SYNC [Icons] AUTO

MAX [Icons] MAX A/C A/C

START/STOP [Icon]

P R N D S

[Gear Shifter]

TECHNOLOGY INFOTAINMENT

Delivering a wealth of information and entertainment, every XF is equipped with our InControl infotainment system, Touch Pro. It features intuitive and advanced integrated technologies to ensure everyone can make the most of their journey.



25.4 cm (10) TOUCH PRO

The standard 25.4 cm (10) Touchscreen at the heart of the centre console supports tap, swipe and pinch-to-zoom gestures and delivers our richest ever audio-visual entertainment. To enhance the in-car experience, Touch Pro offers customisable homescreens and fast response times as well as voice control. Multi-tasking is also made easy thanks to the Interactive Side Panel.



INTERACTIVE DRIVER DISPLAY

The 31.24 cm (12.3) high-definition Interactive Driver Display* can receive and project a vast amount of driving information, entertainment and active safety data including navigation, phone and media. Its high resolution ensures the utmost clarity and its refined processing engine delivers smooth moving pin sharp graphics. To help you find your way more easily, the option of Navigation Pro enables you to display full screen navigation with 3D mapping.



HEAD-UP DISPLAY

To help reduce distraction or the need for you to take your eyes off the road, Head-up Display* presents key vehicle data such as your speed, gear position and navigation directions on the windscreen. It features crystal clear full-colour graphics in high resolution, enabling you to see all driver inputs and information with ease. It can display important information from the Touch Pro Touchscreen and your phone. The feature can be turned on and off dependent on driver preference.

*Standard on Portfolio. Not available on Pure and Prestige.

InControl features, options and their availability remain market dependent – check with your Jaguar Retailer for local market availability and full terms. Information and images displayed in relation to the InControl technology, including screens or sequences, are subject to software updates, version control and other system/visual changes depending on options selected. Mobile network connectivity cannot be guaranteed in all locations. InControl Apps will need to be downloaded from the Apple/Play Store. All in-car features should be used by drivers only when safe for them to do so. Drivers must ensure they are in full control of the vehicle at all times.

CONNECTIVITY

InControl is Jaguar's suite of standard features that connects you to your vehicle and links you seamlessly, and securely, with the outside world. There are a range of packs and options available to choose from. With a selection of apps, even when you're away from your car, some of the InControl features stay with you, making sure the Jaguar experience is more enjoyable than ever.

STANDARD FEATURES

PINPOINT TOUCH CONTROL

Pinpoint touch control allows you to interact with information swiftly. The Touchscreen responds in the same manner as a smartphone or tablet computer, providing multi-touch gestures such as pinch-to-zoom and swipe.

PERSONALISED HOMEPAGE

You can set up your homescreens the way you want them. With over 60 shortcuts and widgets, you can customise your system around the features you use most.

INTERACTIVE SIDE PANEL

A choice of side panels means you can multi-task. For example, your main screen area can be used for navigation, while the side panel provides phone controls. Simply swipe up and down to switch between multiple panels.

MULTIMEDIA

Enjoy a range of multimedia features on the Touchscreen. Connect your device and see details of playlists and music displayed by artist, album and genre.

InControl features, options and their availability remain market dependent - check with your Jaguar Retailer for local market availability and full terms. Information and images displayed in relation to the InControl technology, including screens or sequences, are subject to software updates, version control and other system/visual changes depending on options selected. Mobile network connectivity cannot be guaranteed in all locations. InControl Apps will need to be downloaded from the Apple/Play Store. All in-car features should be used by drivers only when safe for them to do so. Drivers must ensure they are in full control of the vehicle at all times.

ENHANCED PHONE INTERFACE

Making it easier and safer, you can call a favourite contact with a single touch via the customisable homepage. Additional functionality includes direct access to voicemail, conference calling and homescreen integration.

VOICE RECOGNITION SYSTEM

So you can complete tasks without taking your eyes off the road, XF offers intelligent voice recognition. For example, 'Tune to 97.9' or 'Call home'.

NAVIGATION PRO

Navigation Pro allows you to save your favourite places, use swipe and pinch-to-zoom gestures for simple map exploration and display a choice of either 2D or 3D crystal clear map graphics. Navigation Pro functionality is further enhanced by the Connect Pro Pack.

INCONTROL APPS

Jaguar InControl Apps technology allows vehicle-optimised apps on your Android™ or Apple® smartphone to be controlled through the vehicle's Touchscreen, including contacts, calendar and music player via a USB cable. You can also download third-party apps offering a range of services.

AUDIO

A vehicle's cabin is the ideal place within which to experience your personal choice of music and Jaguar XF has the option of three different audio systems to bring your music to life:



SOUND SYSTEM

Excellent acoustic range through eight speakers.

MERIDIAN™ SOUND SYSTEM

Great definition, crystal clear highs and full, deep bass – delivered through the careful arrangement of 10 speakers and a dual channel subwoofer.

MERIDIAN SURROUND SOUND SYSTEM







All the fullness and clarity of a live performance delivered through an arrangement of 16 front, side and rear speakers and a dual channel subwoofer – seamlessly brought together using Trifield™ technology. Exclusive to Meridian, Trifield perfectly blends the centre and surround channels with left and right channels ensuring an optimum, consistent sound experience for each passenger.

Image is representative of Meridian Surround Sound System

For more details on feature availability refer to pages 46-49 or configure your vehicle at jaguar.in

MERIDIAN™

Formed in 1977 in Cambridgeshire, England, Jaguar's audio partner Meridian has pioneered many firsts including active speakers and the world's first digital surround sound processor. Meridian's audio technology input has helped ensure that Jaguar XF is the most superb space within which to experience sound. Meridian Cabin Correction technology was utilised to analyse cabin shape, acoustics and resonance characteristics in order to help remove unwanted sounds. The advanced algorithm ensures that the rhythm, punch and timing of any piece of music are heard precisely how the artist intended, providing a consistently exceptional quality audio experience for all passengers in the vehicle.

	UNIQUE MERIDIAN TECHNOLOGY	SPEAKERS + SUBWOOFER	W
SOUND SYSTEM	N/A	8	180
MERIDIAN™ SOUND SYSTEM	  	10+1	380
MERIDIAN™ SURROUND SOUND SYSTEM	   	16+1	825



DIGITAL SIGNAL PROCESSING

Brings all elements of the audio system together as one, for performance that would otherwise require significantly larger speakers.



MERIDIAN CABIN CORRECTION

The advanced algorithm of Meridian's Cabin Correction tailors the sound experience to the precise acoustics of XF's interior.



MERIDIAN DIGITAL DITHER SHAPING

To maintain the quality of musical recordings, they are converted into a common digital format. Meridian Digital Dither Shaping ensures that digital signal conversions are made smoothly and seamlessly, preserving the finest details of the audio performance. The result is authentic musical conversion, evoking the emotions of the original recording.



TRIFIELD

Exclusive to Meridian, Trifield blends the centre and surround channels seamlessly with left and right channels, delivering a consistent, concert-like experience for all occupants.

SAFETY AND EFFICIENCY DRIVER ASSISTANCE



REAR CAMERA

Rear Camera provides improved visibility when reversing. This valuable parking aid also helps when hitching a trailer. Static lines representing the vehicle's outer perimeter and predicted path are superimposed on the rearward image, to make parking in tight spots as easy as possible.

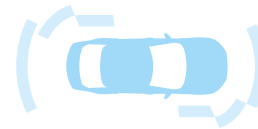

360° PARKING AID

360° Parking Aid uses ultrasonic sensors to the front, rear and sides of the vehicle to alert you to the proximity of objects when parking or exiting from a bay.

Please refer to pages 46-49 for fitment requirements and availability.



PARK ASSIST

Park Assist makes parking in tight spaces easier than ever. XF can accurately steer itself during both parallel and bay parking manoeuvres - the driver only has to control the brakes and accelerator. An exit-assist function can help guide XF while leaving a parallel space.



PEDESTRIAN CONTACT SENSING

Help protect the people outside your car as well as those inside. If the car makes contact with a pedestrian, our industry-leading Pedestrian Contact Sensing system is designed to automatically raise the bonnet to help cushion a potential impact.

PERSONALISATION XF - YOUR CHOICE

 Configure your vehicle at jaguar.in



CHOOSE YOUR ENGINE

Page 44

Select one of XF's powerful, efficient petrol or diesel engines to suit your driving style.

CHOOSE YOUR MODEL & OPTIONS

Page 45

Compare the wealth of standard features and options on XF models.

CHOOSE YOUR COLOUR

Page 50

Express your individuality with one of XF's stunning exterior colours.

4

YOUR ALLOY
WHEELS

Page 52

A set of beautifully designed alloy wheels complements your XF's stunning style.

5

CHOOSE YOUR
INTERIOR

Page 53

Premium materials, leathers, veneers and finishes for every personal taste.

6

CHOOSE YOUR
**JAGUAR GEAR -
ACCESSORIES**

Page 62

Really make it yours by adding style, practicality and versatility with official XF Gear Accessories from your local Jaguar Retailer.

1 CHOOSE YOUR ENGINE

 Configure your vehicle at jaguar.in

> DIESEL ENGINE

2.0 I 4-CYLINDER TURBOCHARGED

MAXIMUM POWER* 132 kW
MAXIMUM TORQUE* 430 Nm
TIME (s) FOR 0-100 km/h Automatic RWD 8.4 s
TOP SPEED Automatic RWD 229 km/h
PURE, PRESTIGE, PORTFOLIO



AUTOMATIC RWD
0-100 km/h



AUTOMATIC RWD
TOP SPEED km/h

> PETROL ENGINES

2.0 I 4-CYLINDER TURBOCHARGED

MAXIMUM POWER 147 kW
MAXIMUM TORQUE 320 Nm
TIME (s) FOR 0-100 km/h Automatic RWD 7.9 s
TOP SPEED Automatic RWD 234 km/h
PRESTIGE



AUTOMATIC RWD
0-100 km/h

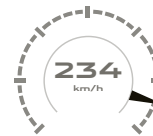

AUTOMATIC RWD
TOP SPEED km/h

2.0 I 4-CYLINDER TURBOCHARGED

MAXIMUM POWER 184 kW
MAXIMUM TORQUE 365 Nm
TIME (s) FOR 0-100 km/h Automatic RWD km/h 6.7 s
TOP SPEED Automatic RWD 244 km/h
PORTFOLIO



AUTOMATIC RWD
0-100 km/h



AUTOMATIC RWD
TOP SPEED km/h

*All Figures are certified by ARAI, the Indian Homologation Authority.

The figures provided are as a result of official manufacturer's tests in accordance with EU legislation. For comparison purposes only. Real world figures may differ.

2 CHOOSE YOUR MODEL

 Configure your vehicle at jaguar.in

> LUXURY



PURE

KEY FEATURES

- 43.18 cm (17) alloy wheels
- Xenon headlights with LED signature
- 25.4 cm (10) Touch Pro
- Luxtec seats
- 10-way electric front seats
- Illuminated metal treadplates with Jaguar script
- Premium carpet mats
- Bright metal pedals
- Suedecloth headlining
- Auto-dimming interior rear view mirror
- Chrome side window surround



PRESTIGE

KEY FEATURES (IN ADDITION TO PURE)

- Driver seat memory
- Perforated grained leather seats
- Rear armrest with cupholders
- Soft grain leather sport steering wheel
- Configurable Ambient Interior Lighting
- Sliding panoramic roof
- Auto-dimming, power fold, heated door mirrors with memory and approach lights
- Adaptive LED headlights with signature DRL
- 4-way electric lumbar adjust
- Meridian™ Sound System
- Rear Camera
- 360° Parking Aid



PORTFOLIO

KEY FEATURES (IN ADDITION TO PRESTIGE)

- 45.72 cm (18) alloy wheels
- Perforated Windsor leather seats
- Windsor leather instrument panel finisher
- Gloss Figured Ebony veneer
- Solar attenuating windscreen
- Driver and passenger seat memory
- 20-way electric front luxury seats
- Four-zone Climate Control
- Head-up Display
- Interactive Driver Display
- Keyless Entry
- Park Assist
- 40:20:40 split fold rear seat

Images feature optional equipment. Please note that standard features may be replaced when selecting alternative trim levels. Standard features may also vary depending on country of purchase, engine variant and transmission, please refer to Specification or configure your vehicle at jaguar.in

2 CHOOSE YOUR OPTIONS

 Configure your vehicle at jaguar.in

KEY STANDARD FEATURES	PURE	PRESTIGE	PORTFOLIO	DESCRIPTION
Intelligent Stop/Start system	●	●	●	Refer to page 18
Hill Launch Assist	●	●	●	Prevents your XF from rolling backwards when pulling away on an incline, helping you to make the perfect hill start every time
JaguarDrive Control with Eco, Dynamic, Normal and Rain, Ice, Snow Mode	●	●	●	
Electric Power Assisted Steering (EPAS)	●	●	●	Refer to page 26
Electric Park Brake with drive-away release	●	●	●	Automatically releases the parking brake without the need for driver input as you press the accelerator to drive away
Emergency Brake Assist	●	●	●	Increases braking pressure in an emergency situation
Hazard lights under heavy braking	●	●	●	
Airbags	●	●	●	Driver and front passenger with seat occupant detector for passenger, front side and full length side window curtain
Torque Vectoring by Braking	●	●	●	Refer to page 31
Dynamic Stability Control and Traction Control	●	●	●	Refer to page 33
Cruise Control and Speed Limiter	●	●	●	
Electric front and rear windows with one-touch open/close and anti-trap	●	●	●	
Rain sensing windscreen wipers	●	●	●	
Body-coloured, heated, electric exterior door mirrors	●	●	●	
Two-zone Climate Control	●	●	—	
25.4 cm (10) Touch Pro	●	●	●	
USB, auxiliary socket and iPod® connectivity	●	●	●	
Bluetooth® telephone connectivity	●	●	●	
Bluetooth® streaming	●	●	●	
Jaguar Smart Key System – Keyless Start	●	●	●	
Partial LED tail lights	●	●	●	
ISOFIX anchor points for rear child seats	●	●	●	
Heated rear windscreen	●	●	●	
Power operated child locks	●	●	●	

● Standard ○ Option — Not available

Please consult your local Jaguar Retailer for details.

For a complete list of optional features and packs refer to the XF Specification Sheet or configure your vehicle at jaguar.in

KEY OPTIONAL FEATURES

	PURE	PRESTIGE	PORTFOLIO	DESCRIPTION
DYNAMIC FEATURES				
8-speed Automatic Transmission with Jaguar Sequential Shift, gearshift paddles and All Surface Progress Control	●	●	●	

EXTERIOR FEATURES AND FINISHERS

EXTERIOR FEATURES AND TRIM				
Electric tilt/slide sunroof	—	●	●	
Chrome radiator grille with Chrome surround	—	●	●	
Chrome side window surround	●	●	●	

GLASS AND EXTERIOR MIRRORS				
Solar attenuating windscreen (front screen only)	—	—	●	Filters sunlight to reduce glare and prevent harmful UV rays from entering the cabin
Auto-dimming heated door mirrors with power fold and approach lights	●	—	—	
Auto-dimming, power fold, heated door mirrors with memory and approach lights	—	●	●	

HEADLIGHTS AND LIGHTING				
Xenon headlights with LED 'J' blade Daytime Running Lights, automatic levelling and headlight power wash	●	—	—	
LED headlights with LED 'J' blade Daytime Running Lights, adaptive lighting, turning light, Auto High Beam Assist and headlight power wash	—	●	●	Refer to page 10

EXTERIOR COLOURS				
				(Please see pages 50-51 for full colour palette)
Solid paint	●	●	●	Refer to page 50
Metallic paint	○	○	○	Refer to page 50-51
Premium paint	○	○	○	Refer to page 51

WHEELS				
				(Please see page 52 to see the full range)
45.72 cm (18) Space saver spare wheel	●	●	●	
Tyre Pressure Monitoring System	●	●	●	

2 CHOOSE YOUR OPTIONS

 Configure your vehicle at jaguar.in

	PURE	PRESTIGE	PORTFOLIO	
SEATING AND VENEERS				
SEATING				
10-way electric front seats with manual headrest height	●	●	—	
4-way electric lumbar adjust (not available with 8-way seats)	—	●	—	
Driver memory	—	●	—	Adjusts driver seat, mirrors and steering column
20-way electric front luxury seats	—	—	●	With manual winged headrest height, 4-way electric lumbar adjust and passenger and driver memory
40:20:40 split fold rear seat with armrest	—	—	●	
VENEERS				
Please see pages 60-61 for full range of veneers				
HEADLINING AND INTERIOR FEATURES				
HEADLINING				
Light Oyster headlining	●	●	●	
Suedecloth headlining	●	●	●	
INTERIOR FEATURES				
Illuminated metal treadplates with Jaguar script	●	●	●	
Premium carpet mats	●	●	●	
Bright metal pedals	●	●	●	
Soft grain leather sport steering wheel	—	●	●	
Electrically adjustable steering column	—	●	●	
Auto-dimming interior rear view mirror	●	●	●	
Four-zone Climate Control with two additional power sockets	—	—	●	
Air Quality Sensor and lockable cooled glovebox	●	●	●	
Manual rear side window sunblinds	●	●	●	
Electric rear window sunblind	●	●	●	
Interior lighting	●	—	—	
Configurable Ambient Interior Lighting (with 10 colours)	—	●	●	Refer to page 17
Smoker's Pack	●	●	●	Includes single front ashtray, single cigar lighter and two single ashtray holders in rear door bins

● Standard — Not available

Please consult your local Jaguar Retailer for details.

For a complete list of optional features and packs refer to the XF Specification Sheet or configure your vehicle at jaguar.in

HEADLINING AND INTERIOR FEATURES CONTINUED

	PURE	PRESTIGE	PORTFOLIO	
SAFETY AND SECURITY				DESCRIPTION
Front Parking Aid	●	●	●	
Rear Parking Aid	●	●	●	
Rear Camera	—	●	●	
Park Assist	—	—	●	Refer to page 41
360° Parking Aid	—	●	●	Refer to page 40
Keyless Entry	—	—	●	

INCONTROL INFOTAINMENT AND CONNECTIVITY

INCONTROL INFOTAINMENT AND CONNECTIVITY				
25.4 cm (10) Touch Pro	●	●	●	Refer to page 35
Analogue Dials with Central TFT Display	●	●	—	
Interactive Driver Display (requires Navigation Pro)	—	—	●	
Sound System	●	—	—	Refer to page 38-39
Meridian™ Sound System	—	●	—	Refer to page 38-39
Meridian™ Surround Sound System	—	—	●	Refer to page 38-39
Navigation Pro	●	●	●	Refer to page 36
CD/DVD player	—	—	●	
InControl Apps	●	●	●	Refer to page 36
Head-up Display with solar attenuating windscreen	—	—	●	Refer to page 35

3 CHOOSE YOUR COLOUR

 [Configure your vehicle at jaguar.in](#)

SOLID

Fuji White

METALLIC

Santorini Black

Indus Silver

Loire Blue

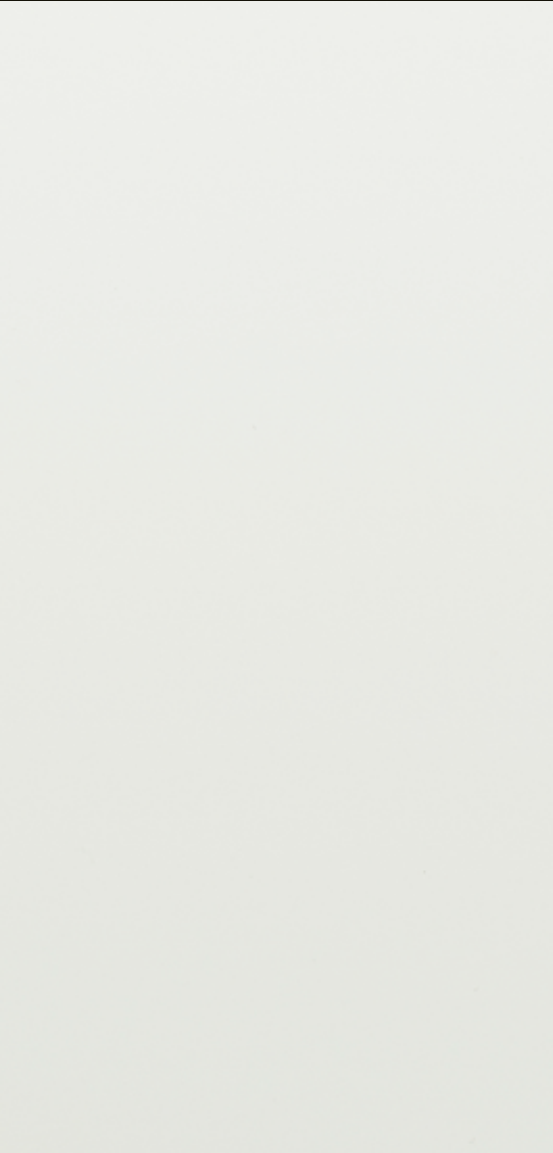

Caesium Blue



Firenze Red



Rossello Red



PREMIUM PALETTE

Carpathian Grey



4 CHOOSE YOUR WHEELS

 Configure your vehicle at jaguar.in



43.18 cm [17] 15 SPOKE
'STYLE 1016'



43.18 cm [17] 9 SPOKE
'STYLE 9005'



45.72 cm [18] 7 SPLIT-SPOKE
'STYLE 7011'

ALLOY WHEEL FINISH	Silver	Silver	Silver
ALLOY WHEEL/SIZE	7.5J x 43.18 cm (17)	7.5J x 43.18 cm (17)	8.0J x 45.72 cm (18)
TYRE SIZE	225/55 R17	225/55 R17	245/45 R18
CODE	029WU	029WV	029WL
Pure	●	—	—
Prestige	—	●	—
Portfolio	—	—	●

● Standard — Not Applicable

5 CHOOSE YOUR INTERIOR



Configure your vehicle at jaguar.in

PURE						
	SEAT WITH TONAL STITCH	UPPER FACIA WITH TONAL STITCH	INTERIOR TRIM AND OPTION CODES	HEADLINING SUEDECLOTH	CARPET	VENEER
Standard						
Luxtec seats	Latte with Latte	Espresso with Espresso	TRA	Light Oyster	Espresso	Gloss Black
PRESTIGE						
	SEAT WITH TONAL STITCH	UPPER FACIA WITH TONAL STITCH	INTERIOR TRIM AND OPTION CODES	HEADLINING SUEDECLOTH	CARPET	VENEER
Standard						
Grained leather seats	Ebony with Ebony	Ebony with Ebony	TRC	Light Oyster	Ebony	Gloss Burr Walnut
	Latte with Latte	Espresso with Espresso	TRD	Light Oyster	Espresso	Gloss Burr Walnut
PORTFOLIO						
	SEAT WITH TONAL STITCH	UPPER FACIA WITH TONAL STITCH	INTERIOR TRIM AND OPTION CODES	HEADLINING SUEDECLOTH	CARPET	VENEER
Standard						
Windsor leather seats	Espresso with Espresso	Espresso with Espresso	TRR	Light Oyster	Espresso	Gloss Figured Ebony
	Siena Tan with Siena Tan	Ebony with Ebony	TRQ	Light Oyster	Ebony	Gloss Figured Ebony

5 CHOOSE YOUR INTERIOR

⚙️ Configure your vehicle at jaguar.in

Interior shown* Ebony Luxtec seats with Ebony facia, Morse Code Aluminium finisher, Gloss Black veneer and Ebony headlining.



PURE

INTERIOR COLOUR COMBINATIONS

STANDARD

1

SEAT WITH TONAL STITCH



Latte

2

VENEER



Gloss Black

3

HEADLINING SUEDECLCLOTH



Light Oyster

4

UPPER FACIA WITH TONAL STITCH



Espresso with Espresso

5

FINISHER



Morse Code Aluminium

6

CARPETS



Espresso

5 CHOOSE YOUR INTERIOR

⚙️ Configure your vehicle at jaguar.in

Interior shown* Ebony grained leather seats with Ebony tonal stitch, Ebony facia, Morse Code Aluminium finisher, Gloss Black veneer and Ebony headlining.



PRESTIGE

INTERIOR COLOUR COMBINATIONS

STANDARD

1

SEAT WITH TONAL STITCH



Ebony with Ebony

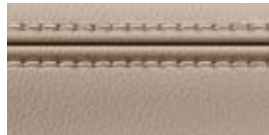

Latte with Latte

2

VENEER



Gloss Burr Walnut



Gloss Burr Walnut

3

HEADLINING SUEDECLCLOTH



Light Oyster



Light Oyster

4

UPPER FACIA WITH TONAL STITCH

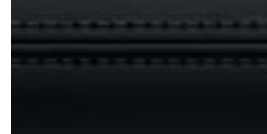

Ebony with Ebony



Espresso with Espresso

5

FINISHER



Morse Code Aluminium

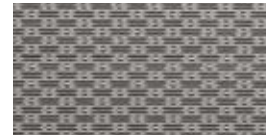

Morse Code Aluminium

6

CARPETS



Ebony



Espresso

5 CHOOSE YOUR INTERIOR

⚙️ Configure your vehicle at jaguar.in

Interior shown*: Latte Windsor leather seats with Latte tonal stitch, Espresso facia, Morse Code Aluminium finisher, Gloss Figured Ebony veneer and Light Oyster headlining.



PORTFOLIO

INTERIOR COLOUR COMBINATIONS

STANDARD

1

SEAT WITH TONAL STITCH



Espresso with Espresso

2

VENEER



Gloss Figured Ebony

3

HEADLINING SUEDECLCLOTH



Light Oyster

4

UPPER FACIA WITH TONAL STITCH



Espresso with Espresso

5

FINISHER



Morse Code Aluminium

6

CARPETS



Espresso

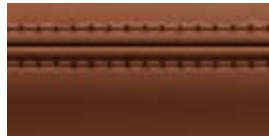

Siena Tan with Siena Tan



Gloss Figured Ebony

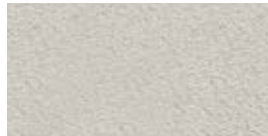

Light Oyster

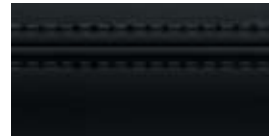

Ebony with Ebony



Morse Code Aluminium



Ebony

*Image shows optional equipment not available in market. Please consult your local Jaguar Retailer for details.

5 CHOOSE YOUR INTERIOR

 Configure your vehicle at [jaguar.in](https://www.jaguar.in)

Gloss Black veneer

Gloss Figured Ebony veneer



Gloss Burr Walnut veneer



6 CHOOSE YOUR JAGUAR GEAR - ACCESSORIES

The genuine range of accessories from Jaguar.

 Configure your vehicle at jaguar.in



Watersports Carrier¹ **C2Z21730**

A versatile system for transporting a variety of water sports equipment including surfboard, kayak or sailboard. Tilts to facilitate loading/unloading.

¹Requires roof cross bars T2H14468.

²Not available for Pure.

VEHICLE SHOWN: XF S IN YULONG WHITE WITH OPTIONAL FEATURES FITTED (MARKET DEPENDENT)



Aluminium Paddle Shifters
T2R6547
T2R6547CAY Red

Replacement steering wheel gearshift paddles offered in a premium aluminium material providing a high quality finish to a key contact point in the vehicle. Manufactured from billet machined aluminium, the paddles are hand brushed for a premium finish and anodised to ensure they will not deteriorate with wear.



Premium Carpet Mats
T2H7172PVJ - Jet
T2H7172AMT - Oyster
T2H7172AAM - Espresso

Luxurious, tailored 2 050 g/m² pile front carpet mats with embossed Jaguar logo and nubuck edge binding. The premium mats provide a well appointed finishing touch to the interior.



Central Armrest Chiller/Warmer
T2H7739

Food and drinks chiller and warmer that acts as a rear centre armrest. With a leather-covered top, it is held in place by the centre seat belt and powered from the rear auxiliary socket. Ideal for long journeys with the family.



Click and Play - iPad Mini
J9C2165

The Click and Play iPad Mini holder is part of the Click and Go range. This removable tablet holder attachment can easily be positioned at multiple angles for in-cabin comfort and rear entertainment.



Personalised Illuminated Sill Treadplates²
T2H17122PVJ

Elegantly styled stainless steel sill treadplate finishers for driver or passenger doors. Illuminates when either the driver or passenger doors are opened. Highlighted by soft Phosphor Blue lighting. Allows you to specify a monochrome 'motif' in a choice of approved typefaces/scripts.



Rubber Mats
T2H7741

Hard wearing Jaguar branded rubber mats provide added protection for your vehicle's carpets.

6 CHOOSE YOUR JAGUAR GEAR - ACCESSORIES

 Configure your vehicle at jaguar.in



Gloss Black Side Vent
T4N5176 - Left Side
T4N5178 - Right Side

Jaguar branded, Gloss Black side power vents provide a dynamic exterior styling enhancement.



Carbon Fibre Side Vent
T2H18318 - Left Side
T2H18319 - Right Side

High grade Carbon Fibre side power vents provide a performance-inspired styling upgrade.



Splash Guards
T2H12952 - Front
T2H12954 - Rear

Jaguar branded splash guards complement the lines of your vehicle, reduce spray and provide protection from dirt and stone chippings.



Gloss Black Mirror Cap
C2D6067PEC - Left Side
C2D6066PEC - Right Side

Gloss Black mirror covers accentuate the dynamic design of the exterior mirrors.



Carbon Fibre Mirror Cap
C2P24176 - Right Side
C2P24177 - Left Side

High grade Carbon Fibre mirror covers provide a performance-inspired styling upgrade.



Rear Tailgate Trim - Gloss Black
T2H17748

Add style and visual distinction with Gloss Black finish rear tailgate trim.

*Requires roof cross bars T2H14468.



Roof Cross Bars
T2H14468

Jaguar branded cross bars required for fitting all roof carrying equipment. Engineered specifically for your vehicle.



Roof Luggage Box*
C2C41628

Spacious 410 l capacity lockable roof luggage box, measuring 175 x 82 x 45 cm.



Roof Sport Box*
C2C41627

Spacious 320 l capacity lockable roof box designed for sports equipment, measuring 206 x 84 x 34 cm.



Ski/Snowboard Holder*
C2A1538

A safe and secure Jaguar branded system for transporting winter sports equipment. Incorporates slider rails for easy loading. For four pairs of skis or two snowboards.



Fork Mounted Cycle Carrier*
C2A1540

Fitted to the roof, the fork mounted cycle carrier provides a simple and secure fitting with the bike front wheel removed, ideally suited to lightweight bikes and 'racing' wheels. A separate carrier is included for the front wheel. Easy to fit, lockable cycle carrier which carries one bike per holder. A maximum of three holders can be fitted.



Tow Bar Mounted Cycle Carrier
C2Z22695 - 2 Bike
C2Z22697 - 3 Bike

Premium tow ball mounted cycle carriers provide a convenient bike carrying solution with quick release loading attachments and secure locking mechanism. Clever design allows carrier to be tilted away from vehicle when fitted, allowing access into the rear tailgate.

TECHNICAL SPECIFICATIONS

 Configure your vehicle at jaguar.in

ENGINES ¹		2.0d 2.0 i 4-CYLINDER TURBOCHARGED DIESEL
Capacity	cm ³	1999
Maximum power	kW	132
r/min	r/min	4 000
Maximum torque	Nm	430
r/min	r/min	1 750 to 2 500
PERFORMANCE		AUTO RWD
0-100 km/h	s	8.4
Top speed	km/h	229
DIMENSIONS ¹		
Overall length	mm	5 067
Overall width (inc. mirrors)	mm	2 091
Overall height	mm	1 457
Wheelbase	mm	2 960
Front track	mm	1 605
Rear track	mm	1 594
Turning circle diameter (kerb-to-kerb)	m	11.61
Boot volume	l	505
WEIGHT ²		
Weight from	kg	1 681
Gross vehicle weight	kg	2 295
ENGINE AVAILABILITY		
Pure		●
Prestige		●
Portfolio		●

● Available — Not Available

¹Please note: All figures are certified by ARAI, the Indian Homologation Authority. A vehicle's actual fuel consumption may differ from that achieved in such tests and these figures are for comparative purposes only.

²Weights reflect vehicles to standard specifications. Optional extras increase weight.

ENGINES		20d 2.0 l 4-CYLINDER TURBOCHARGED PETROL	25d 2.0 l 4-CYLINDER TURBOCHARGED PETROL
Capacity	cm ³	1997	1997
Maximum power	kW	147	184
r/min	r/min	4 500 to 6 000	5 500
Maximum torque	Nm	320	365
r/min	r/min	1 500 to 4 000	1 500
PERFORMANCE		AUTO RWD	AUTO RWD
0-100 km/h	s	7.9	6.7
Top speed	km/h	234	244
DIMENSIONS			
Overall length	mm	5 067	5 067
Overall width (inc. mirrors)	mm	2 091	2 091
Overall height	mm	1 457	1 457
Wheelbase	mm	2 960	2 960
Front track	mm	1 605	1 605
Rear track	mm	1 594	1 594
Turning circle diameter (kerb-to-kerb)	m	11.61	11.61
Boot volume	l	505	505
WEIGHT			
Weight from	kg	1 756	1 786
Gross vehicle weight	kg	2 260	2 260
ENGINE AVAILABILITY			
Pure		—	—
Prestige		●	—
Portfolio		—	●

DIMENSIONS

 Configure your vehicle at jaguar.in

Vehicle Height

With roof antenna 1 457 mm

Overall Width

Including mirrors 2 091 mm



Dimensions were measured with vehicle at unladen weight (measured by VDA standard test method using 200 x 100 x 50 mm blocks).
VEHICLE SHOWN: XF S IN YULONG WHITE WITH OPTIONAL FEATURES FITTED (MARKET DEPENDENT)

Turning Circle
Kerb-to-kerb 11.61 m

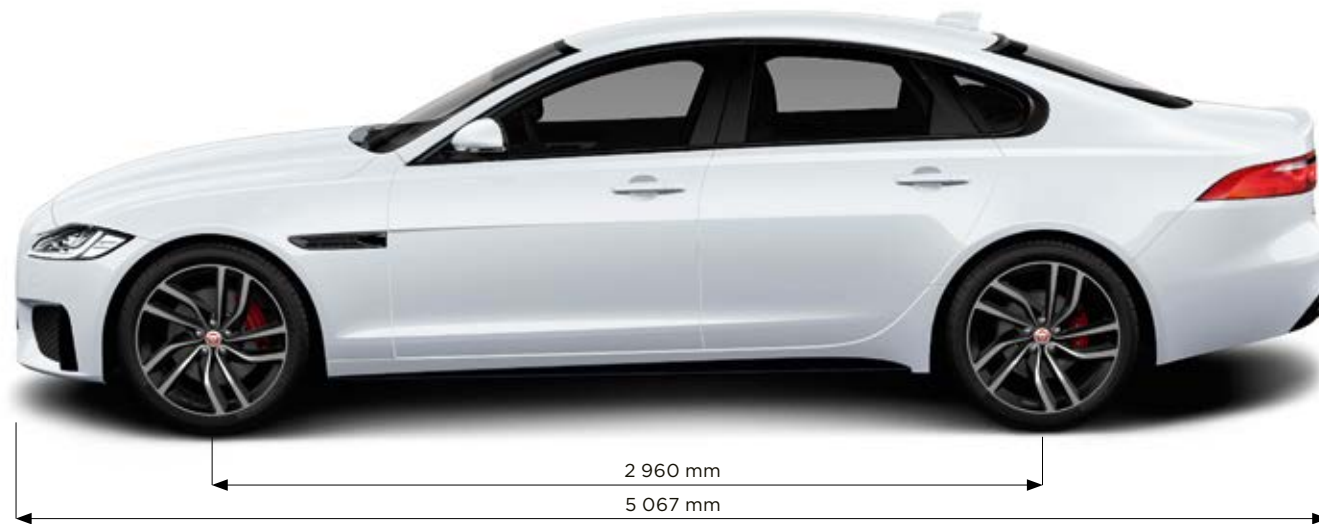

SPECIAL VEHICLE OPERATIONS



Special Vehicle Operations (SVO) designs and engineers products that amplify Jaguar and Land Rover core brand values; focusing on luxury, performance and capability.

Our team of specialists are completely focused on enhancing and personalising our relationship with our most discerning and enthusiastic customers – delivering experiences that our customers will love for life.

SVO is responsible for the creation of a suite of halo products that showcase the pinnacle of Jaguar design and engineering capabilities, enabling our customers to indulge their passion for spectacular new vehicles.

THE NEW SVO TECHNICAL CENTRE

In the heart of the British Midlands is SVO's brand new Technical Centre. This state-of-the-art facility represents a £20 m investment by Jaguar Land Rover, and features four zones designed to support the creation of truly breath-taking vehicles. In addition to the Commissioning and Presentation suites, our manufacturing centre is responsible for the assembly and hand-finishing of SVO halo and Collector's Edition vehicles, and a world-class paint facility ensures an exquisite finish for every car we create.

BESPOKE BY SVO

Bespoke by SVO was born out of an innate understanding of what our most discerning clients value more than anything else – to own something completely unique to them. Something only they can have, reflecting who they are and what they hold most dear. With that in mind, SVO developed innovative Commissioning and Presentation suites enabling creation of the most refined and luxurious vehicles in the world. This special new facility is housed within the new SVO Technical Centre in Warwickshire, England.





THE WORLD OF JAGUAR

Choose XF and you're joining the exciting World of Jaguar.

TRACK DAYS

There's no better way to get to know Jaguar than by taking a drive. The Jaguar Experience offers a range of unique opportunities to really find out what it feels like to get the most out of a Jaguar. Our track experiences allow you to push yourself and cars from the incredible Jaguar range to the limit.

Find out more by visiting jaguar.in/experience

BEHIND THE SCENES

Our factory tours give you the unique opportunity to experience the whole process of how our cars are brought to life - from the moulding of sheet metal to those intricate final touches. At our state-of-the-art production facilities, you'll get to see how skilled technicians and sophisticated machines work seamlessly together to perfect some of Jaguar's most breathtaking cars.

Find out more at jaguar.in/experience-jaguar/factory-tours

ICE DRIVE EXPERIENCES

Take your driving to the next level with the Jaguar Land Rover Ice Drive Experience. Since 2017, we have been offering an adventure in Arjeplog, Sweden, that will test and develop your performance driving skills in extreme conditions. It's a rare chance for owners and enthusiasts to tackle some of the harshest and most challenging tracks on earth, under the skilled guidance of our experts. Our driving instructors are of the highest calibre and will be with you every step of the way - ready to impart years of driving wisdom. You will dance on ice, glide around some of the most awe-inspiring corners imaginable and realise the true exhilarating potential of Jaguar and Land Rover.

If you'd like to be part of the next adventure, find out more by visiting jaguar.in/experience-jaguar





FORMULA E

Jaguar's reputation for performance, technology and design was forged by the world's most challenging circuits and championships. From Le Mans to Formula 1, and now Formula E, the grid is our test-bed. Formula E provides the perfect proving ground for electric vehicle technology in a high performance environment. The racing series accelerates the development of Jaguar's electric powertrains. With every race, Formula E helps Jaguar engineers create better electric vehicles.

Find out more by visiting jaguar.in/jaguar-racing

JAGUAR COLLECTION

The latest range from the Jaguar Collection has been crafted with the same design execution and attention to detail that goes into all of our cars. This is evident in our clothing range, premium leather items and luxury travel goods. To celebrate Jaguar's heritage, we also have a collection that honours past achievements and features race inspired gift items and apparel.

To find out more, visit the online shop at jaguar.in/branded-goods/index

THE JAGUAR MAGAZINE

This is our own vibrant, cosmopolitan and contemporary magazine. Produced by a team of enthusiastic designers and feature writers, it goes behind the scenes at Jaguar as well as providing insight into the world of luxury, design, style and travel. You can enjoy Jaguar Magazine twice a year completely free of charge for the first three years. Ask your local Jaguar Retailer to ensure that you receive your copy.

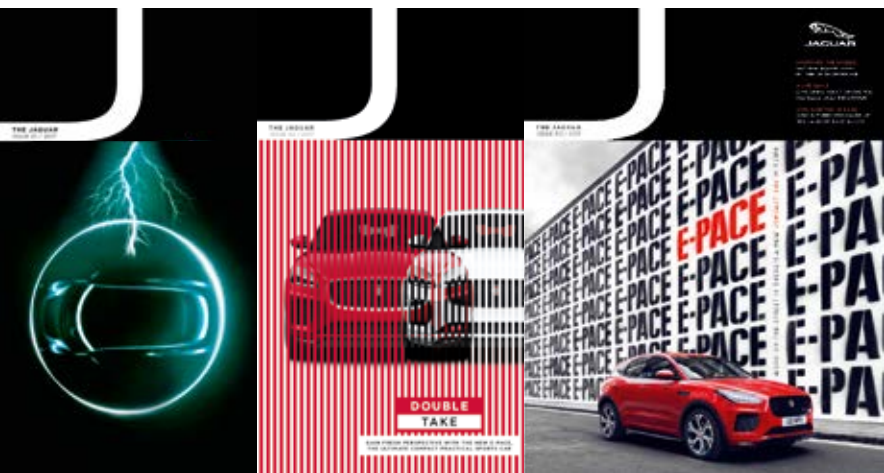



776 XCN

AT YOUR SERVICE

As well as providing a range of exclusive services and lifestyle products, the World of Jaguar makes owning and driving carefree and easy.

GENUINE PARTS

Jaguar Genuine Parts are designed, tested and manufactured to our uncompromising standards for quality, fit and durability. Each part is engineered specifically for your XF to contribute to optimum performance and to help maximise its lifespan.

FLEET & BUSINESS

Jaguars are dynamic and distinctive cars that help companies express the unique character and personality of their business. We are committed to providing customer-focused aftersales services, ensuring that every Jaguar performs to the highest standard and in the most cost-efficient way for businesses. Visit jaguar.in/fleet-and-business for more information.

JAGUAR ASSISTANCE

Jaguar Assistance provides assistance in motoring emergencies, from immobilisation due to breakdown or accident to minor problems such as punctures. You can rely on our roadside assistance, whatever the situation, wherever you happen to be.

JAGUAR FINANCIAL SERVICES

New or used, for personal or business use, we have a finance option that puts you in complete control. Please speak to your local Jaguar Retailer to find out more.

INSURANCE

XF's key components are easily accessible for time-efficient service and repair costs. With a focus on lower repair costs, XF delivers competitive insurance group ratings. To find out more about the compelling business case for XF, please contact your local Jaguar Retailer.

IMPORTANT NOTICE

Jaguar Land Rover Limited is constantly seeking ways to improve the specification, design and production of its vehicles, parts and accessories and alterations take place continually. Whilst every effort is made to produce up to date literature, this brochure should not be regarded as an infallible guide to current specifications or availability, nor does it constitute an offer for the sale of any particular vehicle, part or accessory. Distributors and retailers are not agents of Jaguar Land Rover Limited by any express or implied undertaking or representation.

COLOURS

The colours reproduced here are subject to the limitations of the printing process and may therefore vary slightly from the actual vehicle. The company reserves the right to alter or withdraw any colour finish without notice. Some of these colours may not be obtainable in your country. Please check availability of colours and current specifications with your Jaguar Retailer. Distributors and Retailers are not agents of Jaguar Land Rover Limited and have absolutely no authority to bind Jaguar Land Rover Limited to any express or implied undertaking or representation.

ENVIRONMENTAL INNOVATION AT JAGUAR

Jaguar is committed to reducing dependency on fossil fuels, using fewer natural resources and creating less waste as part of our approach to responsible and sustainable business development.

Search 'Jaguar Environmental Innovation' for more details.

Castrol EDGE Professional exclusively recommended by Jaguar.

Meridian is the registered trademark of Meridian Audio Ltd.

The Bluetooth® word mark and logos are owned by the Bluetooth SIG, Inc. and any use of such marks by Jaguar Land Rover Limited is under license. iPhone is a trademark of Apple Inc., registered in the US and other countries. The navigation system must always be used in conditions that will not affect the driver's ability to drive safely or affect the safety of other road users.

VEHICLES SHOWN FRONT COVER: XF S IN YULONG WHITE WITH OPTIONAL FEATURES FITTED (MARKET DEPENDENT)

VEHICLES SHOWN BACK COVER: XF SALOON R-SPORT IN CORRIS GREY WITH OPTIONAL FEATURES FITTED (MARKET DEPENDENT)

Jaguar Land Rover India Limited:
3rd Floor, Nanavati Mahalaya,
18 Homi Mody Street,
Mumbai - 400 001 India

jaguar.in

© Copyright Jaguar Land Rover Limited 2018

1X2601900000BINEN01P

