

The all-electric EQA



MERCEDES-EQ





Athletic. Electric. The all-electric EQA.

The EQA shapes the urban habitat anew: fully electric, with zero local emissions and virtually silent. Thrillingly dynamic and with convenient charging services, the compact electric SUV even brings more distant destinations within easy reach – and arrives relaxed in the electromobile present. Climb in: into the all new EQA and the all-electric vehicle world of Mercedes-EQ.



Expression of a new lifestyle.

At first glance: a true Mercedes-EQ. At second: an electric statement. Its athletic lines confidently underline its unfettered forward thrust and embody progressive luxury. The black panel radiator grille and the striking LED lighting strip point the way to a new direction and shape the hallmark Mercedes-EQ look. The LED High Performance headlamps integrated as standard at the front signal its progressive stance, above all at night.



Electrifying aesthetics.

Various design lines lend the interior a unique atmosphere and add individual highlights: from dynamic and clear to emotively appealing and elegant. Colours, shapes and materials create a futuristic ambience. The back-lit trim element celebrates the technological progress in an atmospheric way. The Widescreen Cockpit strikingly showcases the latest technology.

Services for a new mobility.

New services and warranties for a carefree mobility: new services have been specially developed for the electric vehicles from Mercedes-EQ, and thanks to these, which are available as of the vehicle purchase, you need worry about as little as possible.

A carefree feeling is also created by special warranties, such as the battery certificate with a performance pledge for up to eight years, or up to 160,000 kilometres driven, for the high-voltage battery – the heart of the EQA.

Overseas model shown.



The image shows the interior of a Mercedes-Benz EQA. A hand is touching the large central touchscreen display. The display shows navigation to Stuttgart, radio station 'DIE NEUE 107.7 MHz', and a temperature of 22°C. The dashboard features three circular air vents with red accents. The steering wheel has a 'START STOP' button and control stalks. The instrument cluster on the right shows a speedometer at 0 km/h, a tachometer at 15.6 km, and a range of 654 km. The ambient lighting is a vibrant red.

Perfect for you: The all-electric EQA with MBUX.

MBUX stands for Mercedes-Benz User Experience. In short: this is all about you. Via the large display with a touchscreen you can control all the functions intuitively – via touch, but also using gestures or speech with “Hey Mercedes”. The system can also learn and continually adapts to suit the driver’s needs even better. Practical interfaces for the telephony and digital media are facilitated by simple Smartphone Integration and round off the special infotainment experience.

A man in a patterned shirt is standing next to a Mercedes-Benz Wallbox charging station. He is holding a charging cable that is plugged into the car's charging port. The scene is set in a modern, brightly lit environment with a blue and white color palette.

This is how easy charging can be.

Home becomes a place where you recharge more than just your own batteries. Via the Mercedes-Benz Wallbox with a charging output of up to 11 kW,* you charge your EQA up to three times faster than at a conventional socket. So making charging convenient and simple.

*Subject to power supply availability, technical requirements and local regulations.





Exemplary safety. The all-electric EQA.

The driving assistance systems in the EQA think ahead, have an eye on what is happening in the traffic and can not only relieve the burden on you in day-to-day life, but also provide effective support in hazardous situations. This means that the occupants and other road users can be protected effectively – via the exit warning function, for example, even when you have already reached your destination.



Extended standard equipment.

The extended standard equipment enhances comfort with the Progressive design and equipment line, including a leather steering wheel and luxury seats, reversing camera and EASY-PACK tailgate.

STANDARD SPECIFICATION

- Progressive design and equipment line
- Reversing camera
- Ambient lighting
- EASY-PACK tailgate
- Adaptive Highbeam Assist
- Speed Limit Assist
- Load Compartment Package

Widescreen Cockpit.

In addition to the extended standard equipment, two brilliant 10.25-inch displays in the form of a Widescreen Cockpit enhance the vehicle interior. Further intelligent assistants tangibly increase ride comfort.

FURTHER HIGHLIGHTS

- Widescreen Cockpit, consisting of media display and fully digital instrument display, each with 10.25-inch screen diagonal
- Parking Package with reversing camera
- Mirror Package
- Blind Spot Assist

Comfort.

The high-quality sound system also forms a rich backdrop to the journey, while your smartphone is wirelessly charged.

- THERMOTRONIC automatic climate control
- KEYLESS-GO Convenience Package
- Advanced Sound System
- Wireless charging system for mobile devices
- Widescreen Cockpit, consisting of media display and fully digital instrument display, each with 10.25-inch screen diagonal
- Parking Package with reversing camera

Vision Package.

The Vision Package offers the top level of equipment. It supplements all the previous equipment packages with additional highlights such as the Burmester® surround sound system and the panoramic sliding sunroof. No wish is left unanswered.

HIGHLIGHTS OF THE VISION PACKAGE

- Panoramic sliding sunroof
- Parking Package with 360° camera
- Burmester® surround sound system



Progressive design and equipment line.

Its design is as progressive as its claim. In the standard specification, the Progressive design and equipment line adds exclusive highlights: with luxury seats in ARTICO man-made leather and including Seat Comfort Package, or the leather steering wheel. The exterior shines with features such as roof rails in polished aluminium.

EXTERIOR HIGHLIGHTS

Roof rails in polished aluminium

19" AMG 5-twin spoke alloy wheels

Front and rear apron with chrome insert

Shoulderline and windowline trim elements in polished aluminium

INTERIOR HIGHLIGHTS

Luxury seats including Seat Comfort Package

Upholstery in ARTICO man-made leather

Multifunction sports steering wheel in leather with black topstitching and 2-part chromed trim

Air vents in silver chrome with outer ring in silver chrome and air guide ring in high-gloss black

Side trim in grained black with chromed insert

AMG Line Sports Package.

Confidently shows what it's made of: the EQA with AMG Line. On the outside, features such as the AMG-specific front apron and the AMG-specific black panel radiator grille reinforce the strong forward thrust. On the inside the sports seats and the multifunction sports steering wheel make it clear that standing still is not an option.

EXTERIOR HIGHLIGHTS

AMG-specific front apron with trim elements in chrome as well as functional AIR CURTAINS

AMG-specific black panel radiator grille in twin-blade design and with surround in high-gloss black

AMG rear apron in diffuser look with trim part in chrome

20" AMG multi-spoke alloy wheels, painted in high-gloss black with a high-sheen finish

Side trim in grained black with chromed insert

INTERIOR HIGHLIGHTS

Sports seats with adjustable head restraint including Seat Comfort Package

Upholstery in black ARTICO man-made leather/DINAMICA microfibre with red contrasting topstitching

3-spoke multifunction sports steering wheel in nappa leather, with flattened bottom section, with perforation in the grip area and Touch Control buttons

AMG brushed stainless steel pedal assembly with rubber studs

Air vents in silver chrome with outer ring in silver chrome and air guide ring in high-gloss black



Edition 1.

The unique Edition 1, available for a limited time, combines elements of the Night Package with elements of the AMG bodystyling. The exterior has a sporty look with AMG-specific equipment features. In the vehicle interior the back-lit trim part and blue topstitching in seats and doors add clear highlights.

EXTERIOR HIGHLIGHTS

AMG-specific front apron with trim elements in high-gloss black as well as functional AIR CURTAINS

AMG-specific black panel radiator grille in twin-blade design and with surround in high-gloss black

AMG-specific rear apron in diffuser look with trim part in high-gloss black

50.8 cm (20-inch) AMG multi-spoke light-alloy wheels in rosé gold

Side trim in grained black with insert in high-gloss black

INTERIOR HIGHLIGHTS

Upholstery in neva grey leather with CYBER CUT blue

Armrest in ARTICO man-made leather black with blue topstitching

Widescreen Cockpit, consisting of media display and fully digital instrument display, each with 10.25-inch screen diagonal

3-spoke multifunction sports steering wheel in nappa leather, with flattened bottom section, with perforation in the grip area and Touch Control buttons

Trim element back-lit

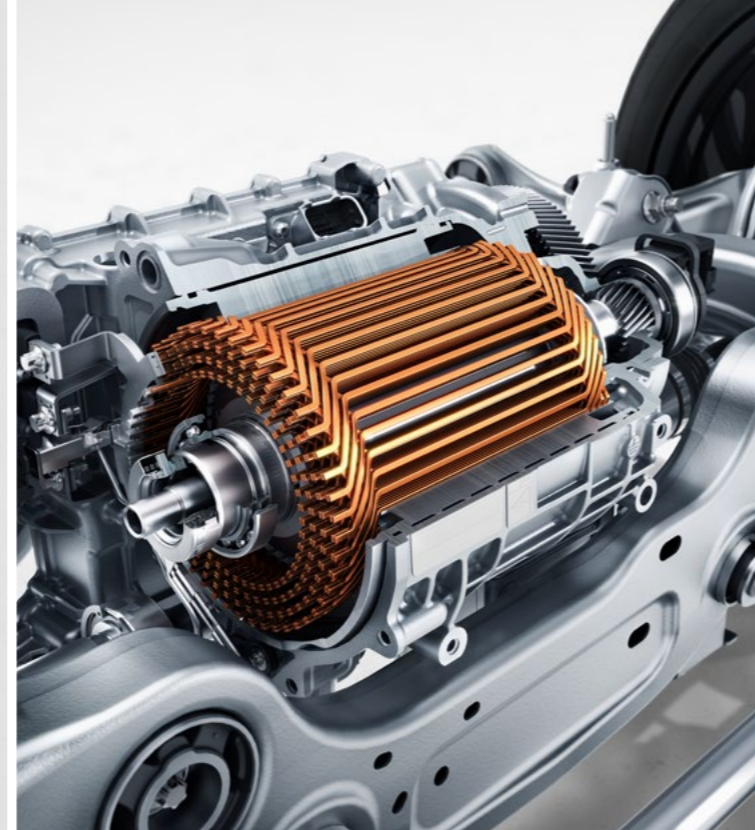

Electric drivetrain.

Efficiently electric: the drive technology of the EQA offers impressive power delivery for more efficiency, safety, comfort and driving pleasure – hallmark Mercedes-EQ. The electric drivetrain (eATS) with an asynchronous motor and integrated parking lock sits on the front axle in the case of the EQA 250. From there it puts an effortlessly superior system output of 140 kW on the road. The full torque is already available with the first touch of the accelerator pedal, without the slightest feeling of a moment's hesitation during acceleration. Further model variants with higher output levels and all-wheel drive are already being planned. Furthermore the EQA with DYNAMIC SELECT supports you through various drive programs with different characteristics – from efficient to sporty for more driving pleasure in bends and comfort on long journeys.

Driving Assistance Package.

A further step towards fully automated driving. The Driving Assistance Package sets new standards where safety and ride comfort are concerned. Cameras, radar and ultrasound record the surroundings and provide situation-appropriate support for speed adjustment, steering and when there is the danger of a collision. To supplement this, various data from maps, navigation system and Live Traffic Information are used to assess routes and traffic in real time. All information is intelligently networked. For you this means tangible relief and optimum protection for occupants and other road users.

Technical data.

	EQA 250
Rated output (peak output) (electric) (kW [hp])	140 [190]/3600-10300
Rated torque of electric motor (Nm at rpm)	375
Acceleration from 0 to 100 km/h (s)	8.9s
Top speed (km/h)	160
Combined CO ₂ emissions (g/km)	0
Combined electrical consumption max.-min. ¹ (kWh/100 km)	16.2
Electric range (km)	480
Battery type/net battery capacity (kWh)	66.5
Cd value	0.28
Boot capacity (l)	340
Kerb weight ⁶ (kg)	2040
Gross vehicle weight (kg)	2470

Dimensions.

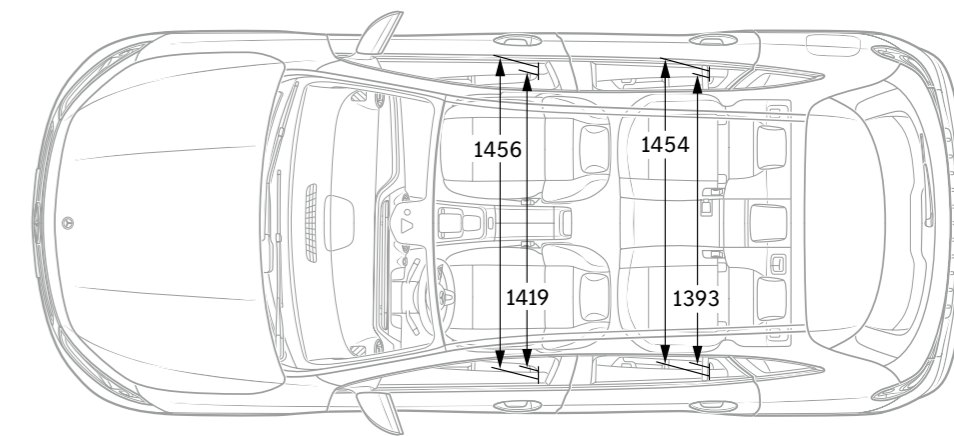
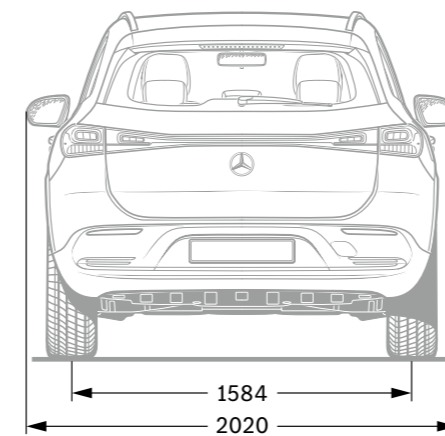
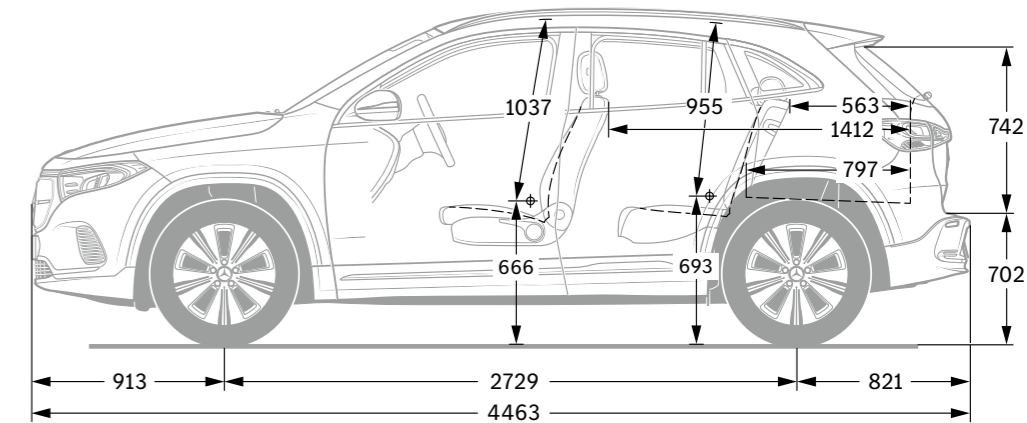
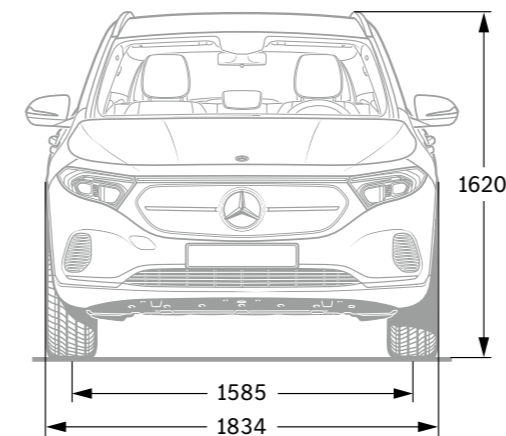

¹ The declared fuel and energy consumption figures are determined by testing under standardised laboratory conditions to comply with ADR 81/02. Real world energy consumption is influenced by many additional factors such as individual driving style, load, traffic, ambient temperature and vehicle condition. The declared energy consumption figure should only be used for the purpose of comparison amongst vehicles.

All figures in millimetres. The pictured dimensions are mean values. They are valid for vehicles with standard equipment and in unladen condition.

Please note: Changes may have been made to the product since the editorial deadline (24.05.2019). The manufacturer reserves the right to make changes to the design, form, colour and the product specification during the delivery period, provided these changes, while taking into account the interests of the vendor, can be deemed reasonable with respect to the purchaser. The illustrations may show accessories and items of optional equipment which are not part of standard specification. This publication is distributed internationally. For current and more specific information, please contact your nearest authorised Mercedes-Benz retailer. www.mercedes-benz.com.au